



Passenger Impact Program

Rider Experience and Operations Committee

1/16/2025



Why We Are Here

Upcoming Work Requiring Service Disruption

- 2 Line integration – Phase 2 (Q1 2025)
- 130th Station Roofing (Q1 2025)
- UW area OCS (Q1 2025)
- Look ahead to Remainder of 2025 & 2026

The purpose of this presentation is for information only.

No Board action is expected today.

Work in Q1 2025 – Operation Chilly Overview



Work in Q1 2025 – Operation Chilly

130th Infill Station Roofs

- **Why this is necessary:** Install roofing material on the station roofs
- **Passenger benefit:** Maintain life of the station
- **What is the impact:**
 - Jan 4 to Feb 27
 - Single tracking with 12-minute headways
 - Weekdays 5:30 pm to close of service
 - Select weekends



Work in Q1 2025 – Operation Chilly

2 Line Downtown Tunnel Signal & Electrical Integration

- **Why this is necessary:** Complete work to tie in 2 Line signal and electrical systems to downtown tunnel and perform full systems integration testing.
- **Passenger benefit:** 2 Line operations start safely and on schedule.
- **What is the impact:**
 - January 10 to 12 – bus bridge Westlake to SoDo
 - January 17 to 19 – bus bridge Cap Hill to SoDo
 - February 14 to 16 – bus bridge Cap Hill to SoDo



Work in Q1 2025 – Operation Chilly

2 Line Downtown Tunnel Signal & Electrical Integration

- January 10 to 12
Westlake to SoDo
- January 17 to 19
Cap Hill to SoDo
- February 14 to 16
Cap Hill to SoDo

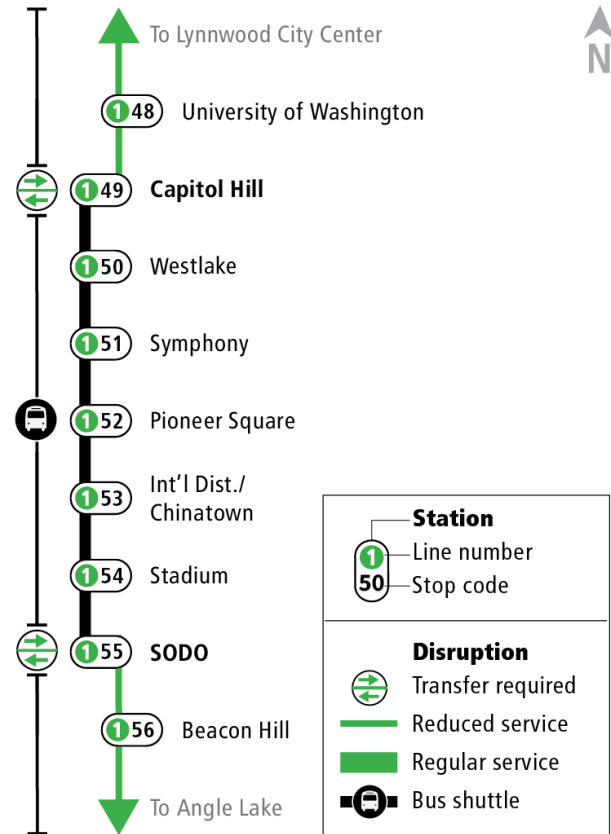

Work in Q1 2025 – Operation Chilly

Repair OCS Wire Near UW Station

- **Why this is necessary:** Repair overhead train power and improve a section of wire that's wearing too fast
- **Passenger benefit:** Trains go back to normal speed in this area, and likelihood of future impacts is reduced
- **What is the impact:**
 - Feb 1 & 2
 - Full closure between Cap Hill and U-District
 - Bus shuttle will serve passengers

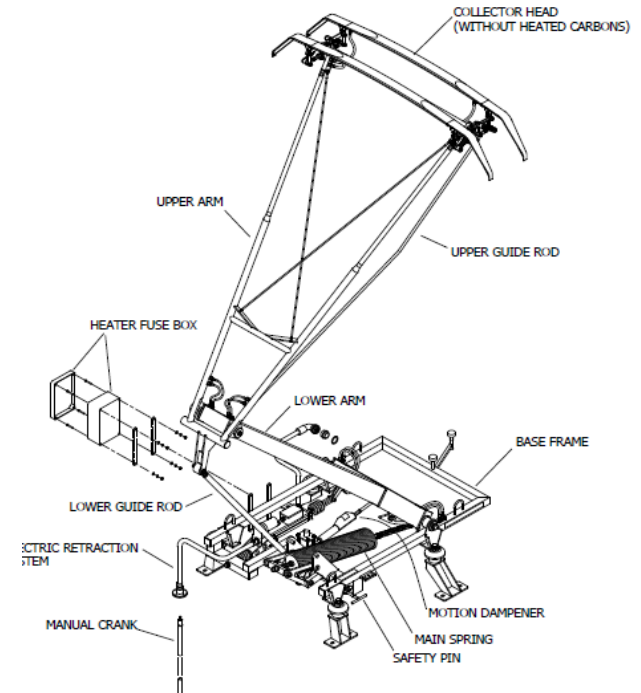

Work in Q1 2025 – Operation Chilly Repair OCS Wire Near UW Station

UW OCS
Feb 1 to 2

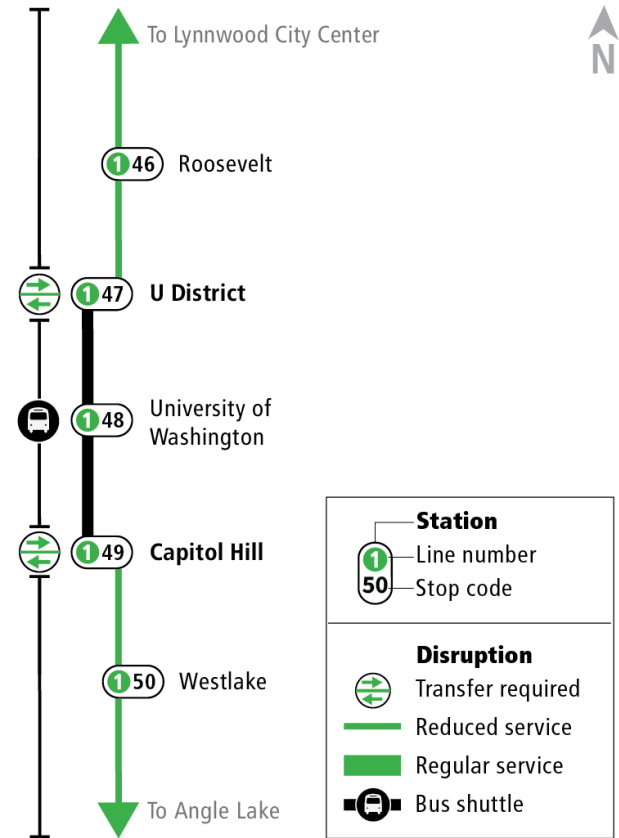

Look Ahead to Remainder of 2025/26

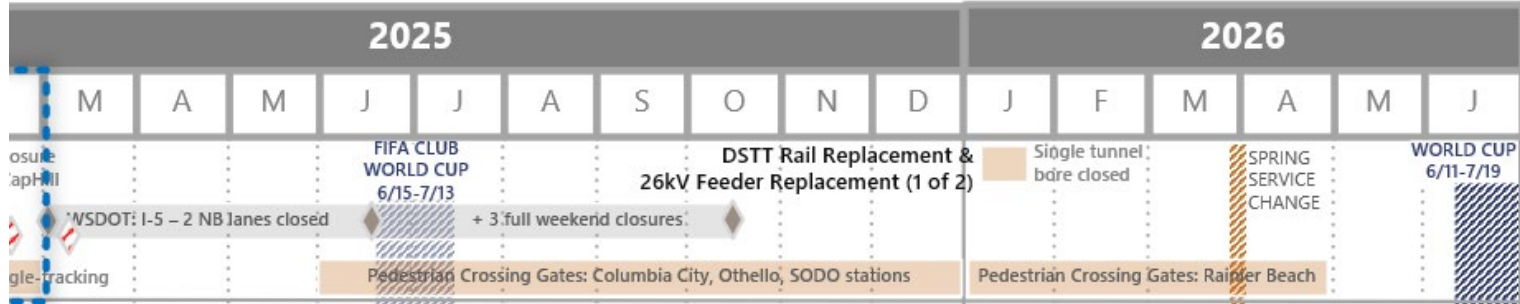

Next Steps

- Gather lessons learned from Operation Chilly impact improve service to passengers during future impacts
- Avoid impacting service during major WSDOT I-5 Lane closures in north Seattle from March to November 2025
- Continue planning impacts for the remainder of 2025 and 2026

Thank you.



 [soundtransit.org](https://www.soundtransit.org)

