



Passenger Impact Program

Rider Experience and Operations Committee

12/5/2024



Why We Are Here

Upcoming Work Requiring Service Disruption

- UW Station Power System Repairs (Dec 2024)
- 2 Line integration – Phase 2 (Q1 2025)
- 130th Station Roofing (Q1 2025)
- UW Crossover (Q1 2025)

The purpose of this presentation is for information only.

No Board action is expected today.

Work Planned for Q4 2024

Repair OCS Wire Near UW Station

- **Why this is necessary:** Repair overhead train power due to damage in September
- **Passenger benefit:** Trains go back to normal speed in this area
- **What is the impact:**
 - Dec 7 and 8 – single tracking between U-District and Cap Hill stations
 - Supplemental bus bridge running to augment train

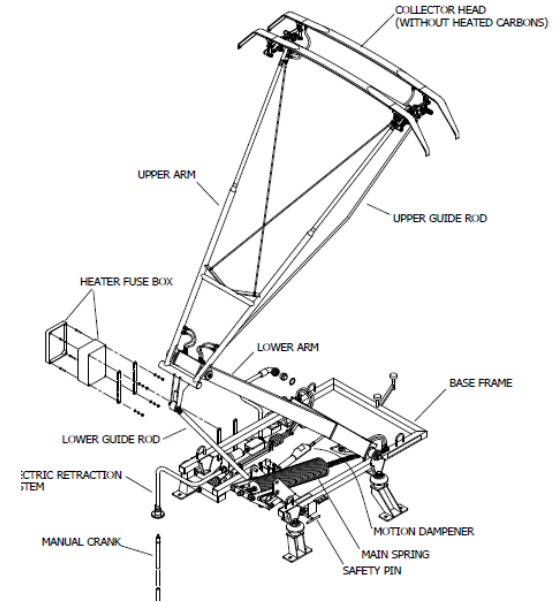

Work Planned for Q4 2024

Repair OCS Wire Near UW Station

What is the impact (continued)

- Service plan includes two forced transfers at UDS and Cap Hill and service levels of:
 - Lynnwood to University District Station (every 22 minutes)
 - University District Station to Capitol Hill (every 22 minutes on SB track)
 - Capitol Hill to Angle Lake Station (every 15 minutes)

Work Planned for Q4 2024

Repair OCS Wire Near UW Station

What is the impact (continued)

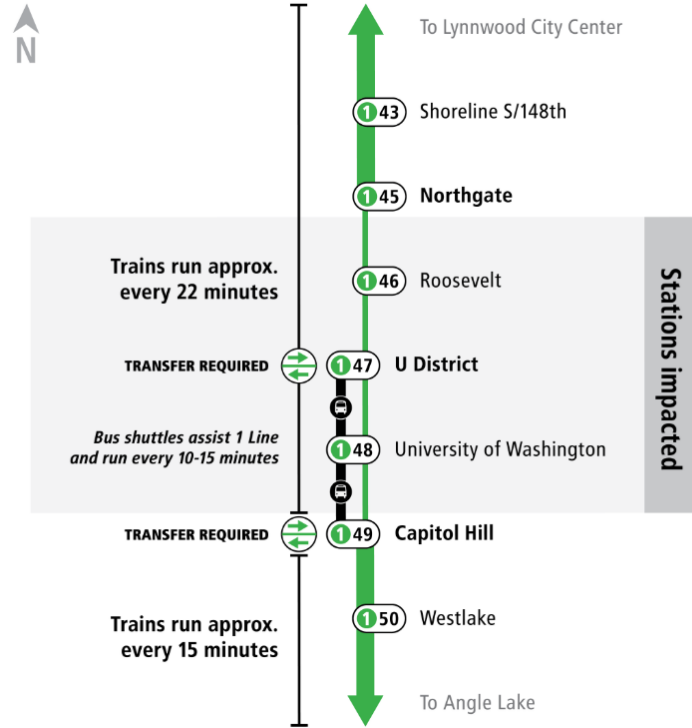

Work Planned for Q1 2025

Downtown Tunnel Signal & Electrical Integration (Phase 2)

- **Why this is necessary:** Complete work to tie in 2 Line signal and electrical systems to downtown tunnel and perform full systems integration testing.
- **Passenger benefit:** 2 Line operations starts safely and on schedule.
- **What is the impact:**
 - January 10 to 12 – bus bridge Westlake to SoDo
 - January 17 to 19 – bus bridge Cap Hill to SoDo
 - February 14 to 16 – bus bridge Cap Hill to SoDo
 - February 22 to 23 held as contingency



Work Planned for Q4 2024

2 Line Downtown Tunnel Signal Integration (Phase 2)

- What is the impact (continued)
 - Passengers will be served downtown by a bus bridge running every 10 to 15 minutes between SODO/Westlake and Capitol Hill).
 - Link trains will run every 15 minutes on either side of the downtown tunnel

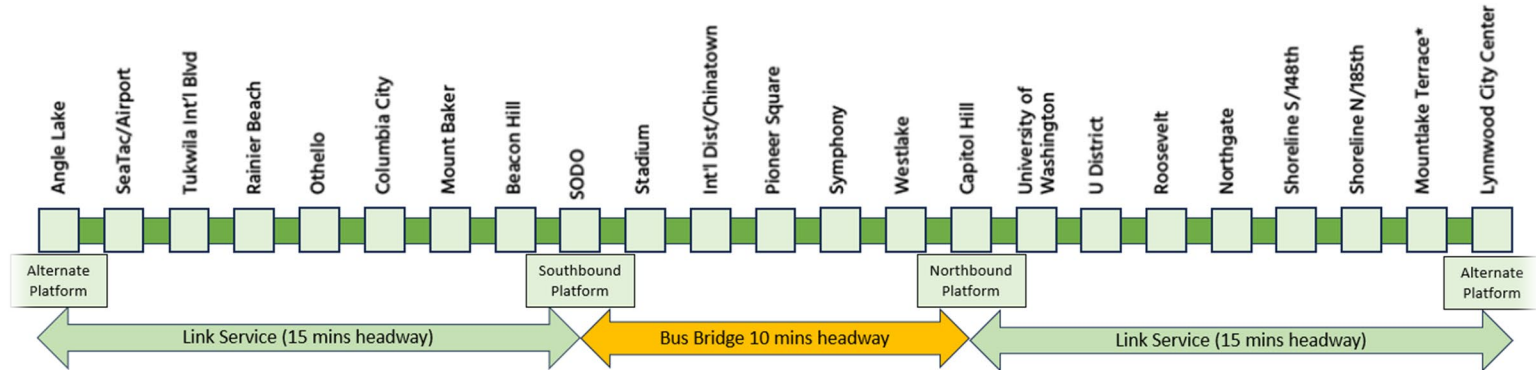

Work Planned for Q1 2025

130th Infill Station Roofs

- **Why this is necessary:** Install roofing material on the station roofs
- **Passenger benefit:** Maintain life of the station
- **What is the impact:**
 - Single tracking service
 - 12 minute headways
 - Jan 4 to Feb 27, 2025
 - Weekdays 7pm to 4:30am
 - Weekends: Jan 4, 25, and Feb 8, 15



Work Planned for Q1 2025

UW Interlocking

- **Why this is necessary:** Repair overhead contact wire
- **Passenger benefit:** Maintain system and avoid unplanned outages
- **What is the impact:**
 - Full closure Capitol Hill Station to University District Station
 - Feb 1 & 2
 - Bus bridge to provide service
 - Exact train and bus headways are under development

Next Steps

- Continue working on details of upcoming tunnel closures for Q1 2025.
- Incorporate lessons learned from November weekend closure:
 - More contingency planning
 - More planning around testing
- Prepare for I-5 closures from March to November 2025



Thank you.



 [soundtransit.org](https://www.soundtransit.org)

